

name: _____

FUN

Phonics

a b c

A a



B b

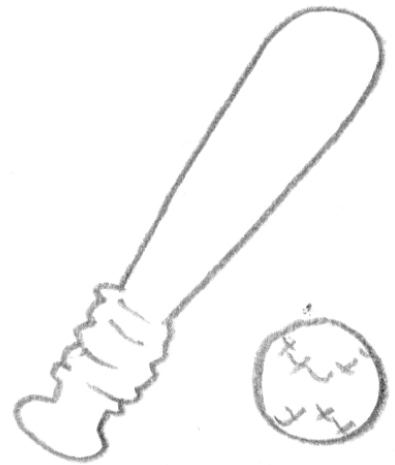

FUN PHONICS

a b c

To the teacher or parents:

This workbook will help students recognize the alphabet, associate a few items with each letter, introduce them to alphabet sounds, and practice some writing balance.

- Students should trace the large letter with their finger three times each.
- Show the students the items that start with that letter. Color the pictures for homework.
- Point out the sound the letter makes and use the speaker icon to help you indicate it's the sound.
- Have the students find and circle the letter.
- Have students practice the patterns. Emphasize starting and stopping at the right points.

Illustrations by Mark Cox

Trace A with your finger three times.

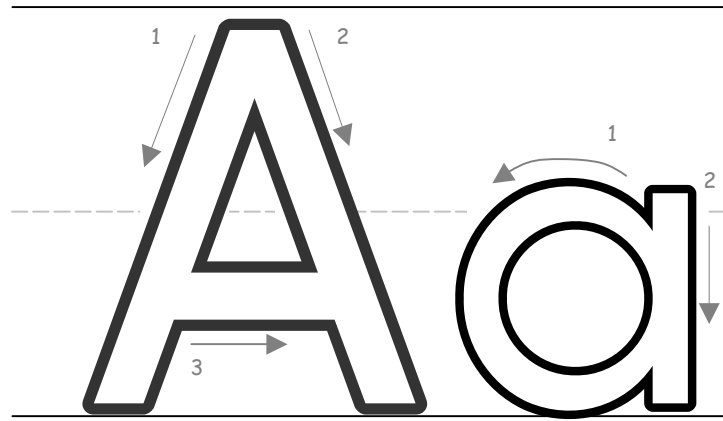

Color these things that start with A.

apple



alligator



ant



A

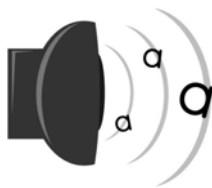

What sound does A make?

Circle the As.

S A V M A B W A X N

a c e a p a o b d a

Follow the pattern.

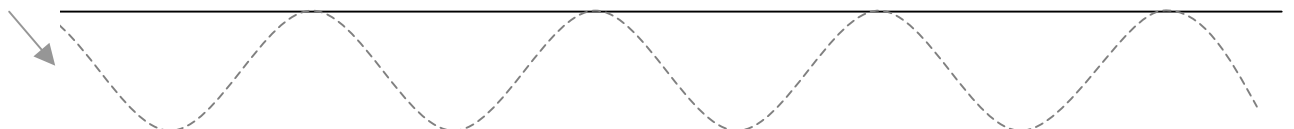

Trace B with your finger three times.

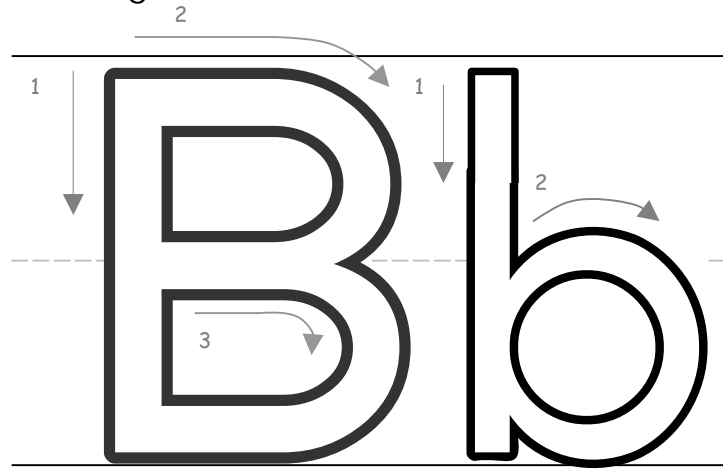

Color these things that start with B.

bear

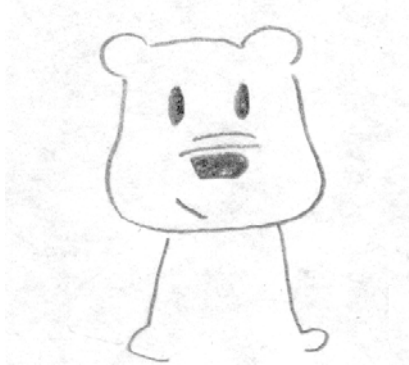

bat

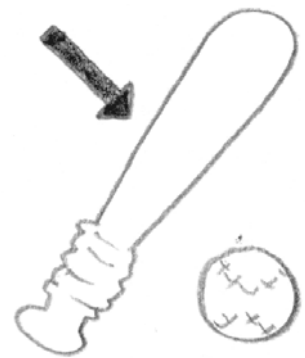

balloon

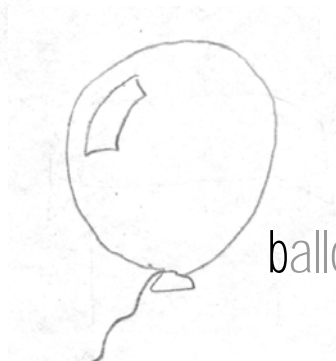

B

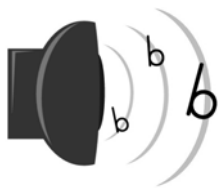

What sound does B make?

Circle the Bs.

C D B M B G H P B Q
b f l a d b o b s h

Follow the pattern.

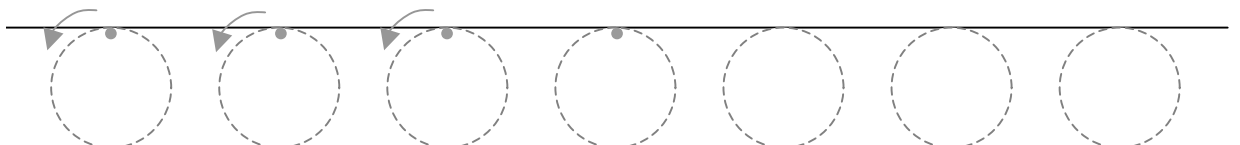

Trace C with your finger three times.

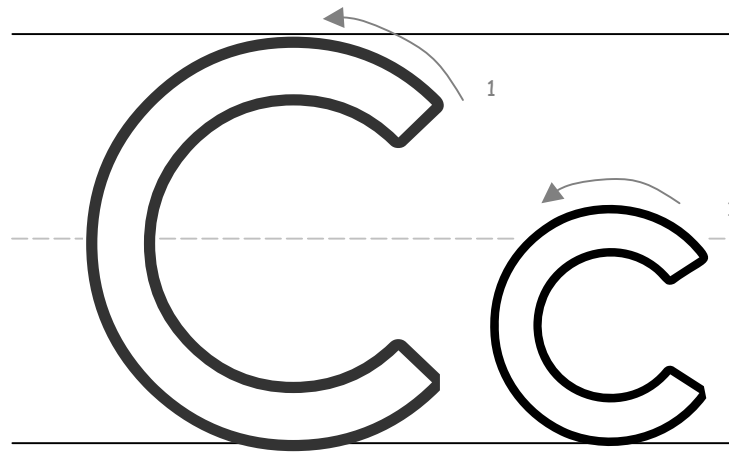

Color these things that start with C.

cat



cookie

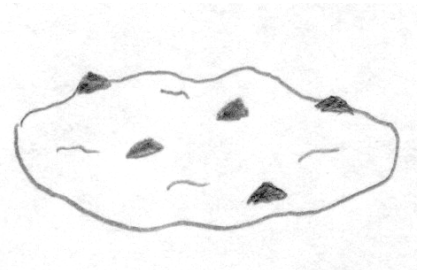

cook

C

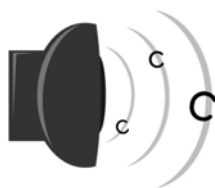

What sound does C make?

Circle the Cs.

C D O P C G C P J C
e c d a c u c g p c

Follow the pattern.

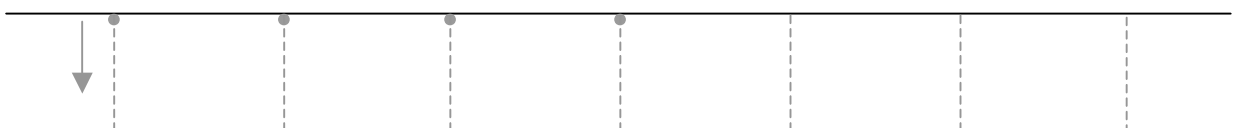

Trace D with your finger three times.

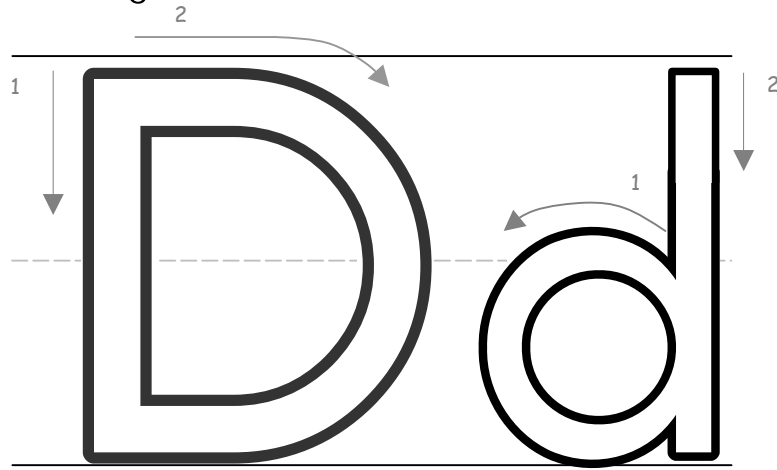

Color these things that start with D.

dog



duck

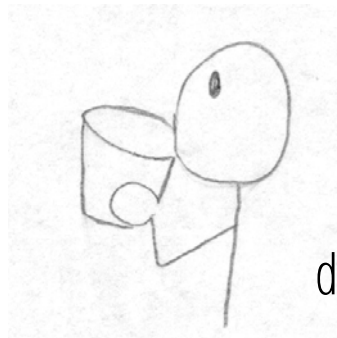
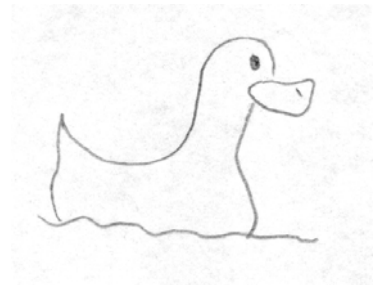

drink

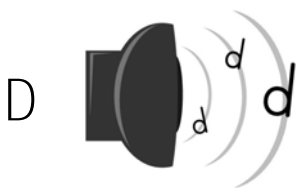

What sound does D make?

Circle the Ds.

B D O C D F Q D B D
d p o a d g d b h d

Follow the pattern.

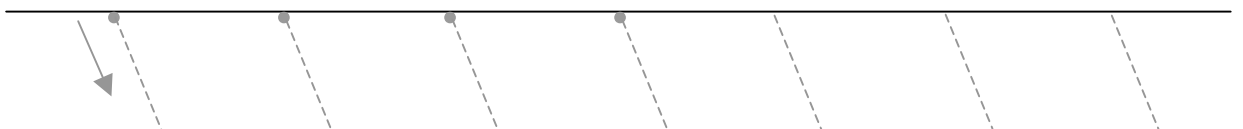

Trace E with your finger three times.

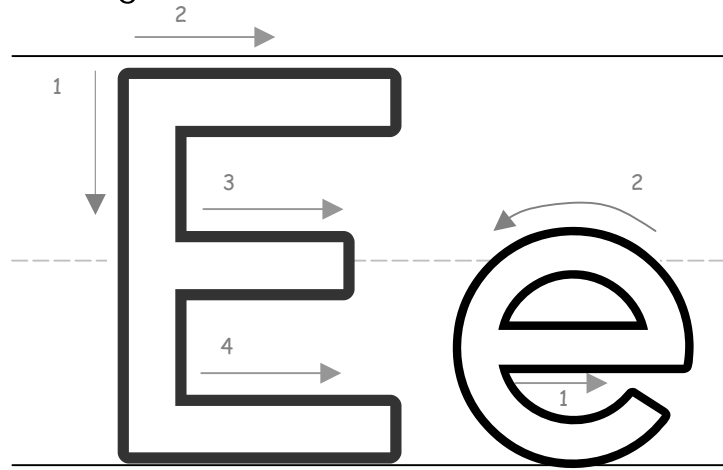

Color these things that start with E.

egg



elbow

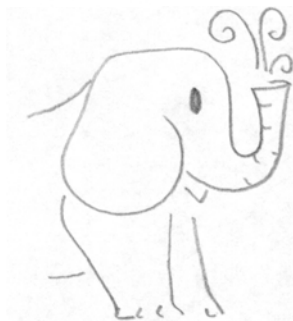
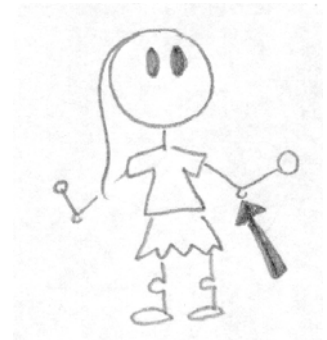

elephant

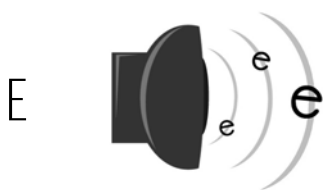

What sound does E make?

Circle the Es.

E D B F E H E P Z E
a o e i e f g e c e

Follow the pattern.

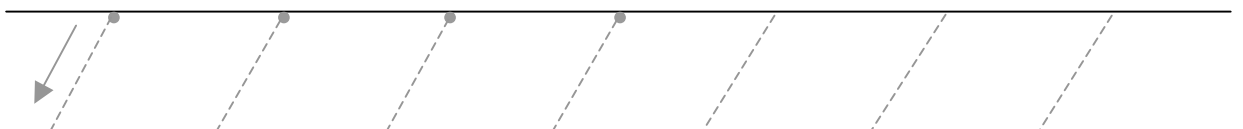

Trace F with your finger three times.

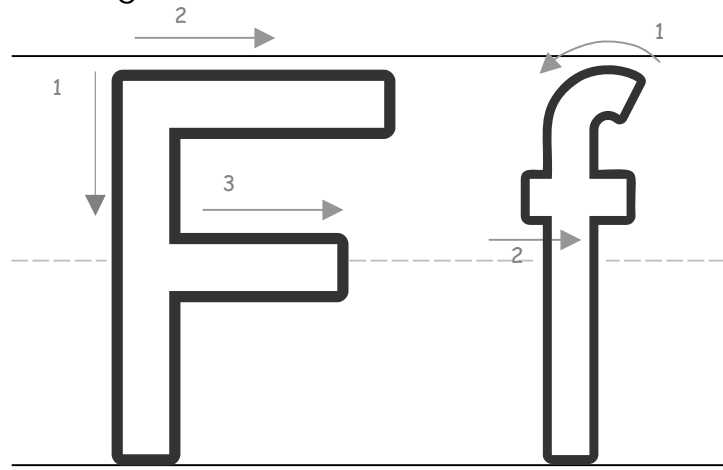

Color these things that start with F.

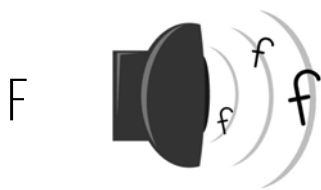
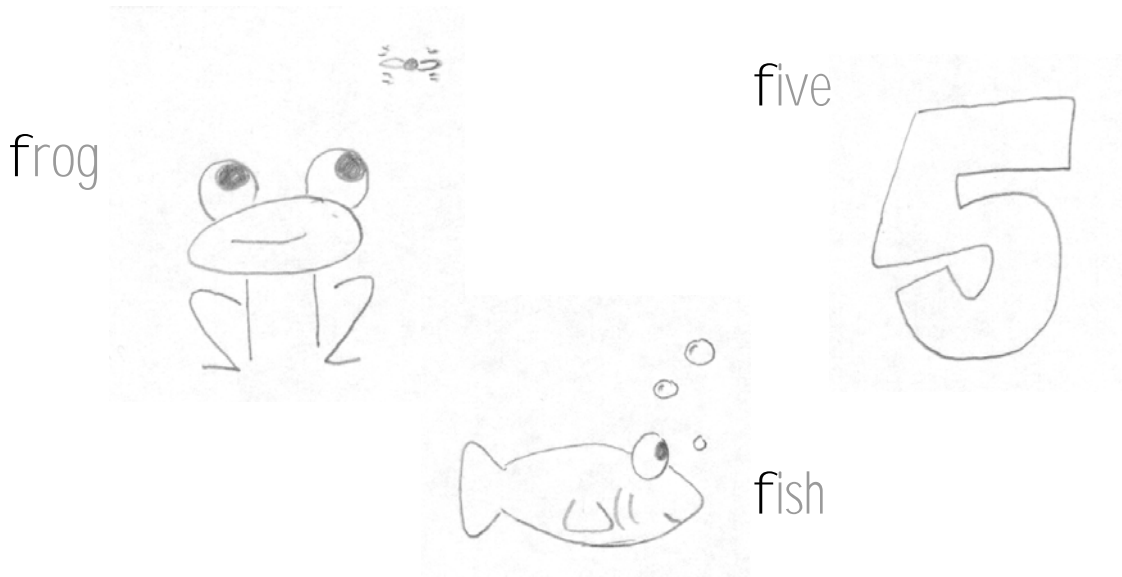

What sound does F make?

Circle the Fs.

F G E L F H F P B F
f i t f h l f d k f

Follow the pattern.

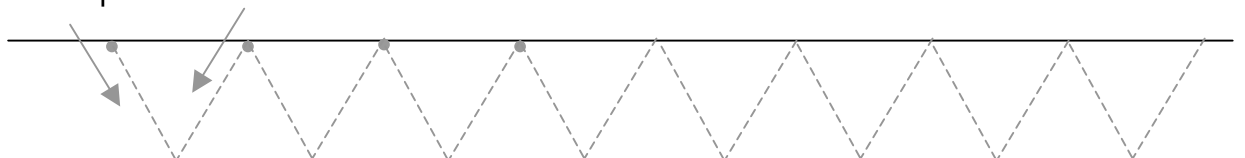

Trace G with your finger three times.

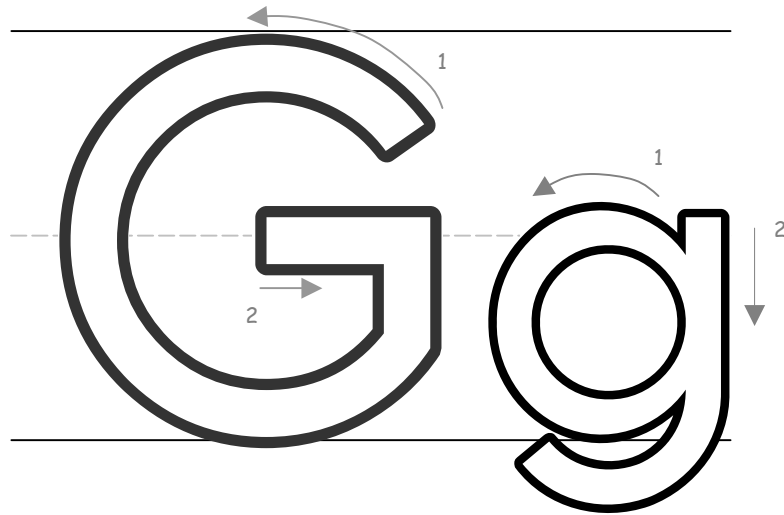

Color these things that start with G.

gorilla

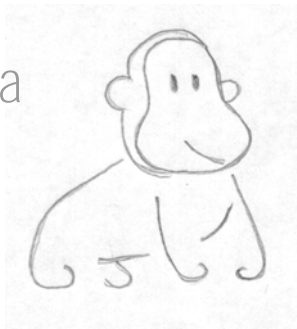

grapes

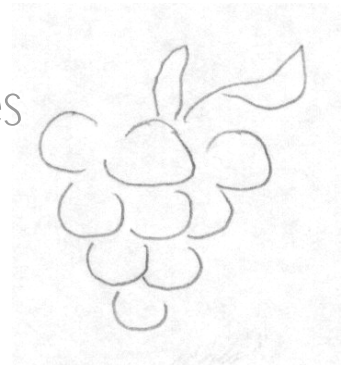

good

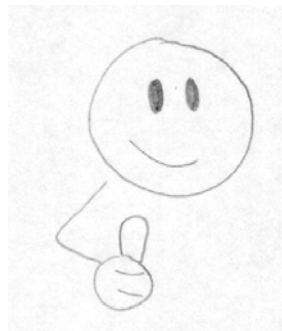

G

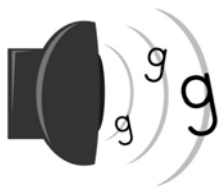

What sound does G make?

Circle the Gs.

O G D M G K E G Q G
g j a o g q h g p g

Follow the pattern.

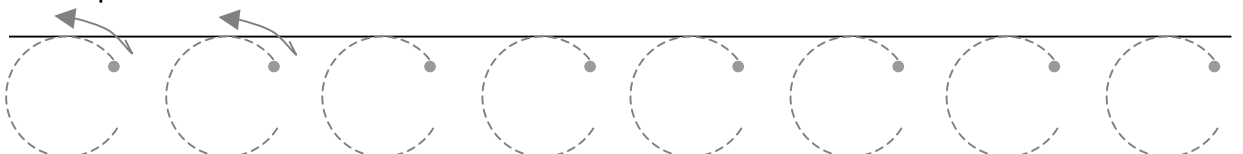

Trace H with your finger three times.

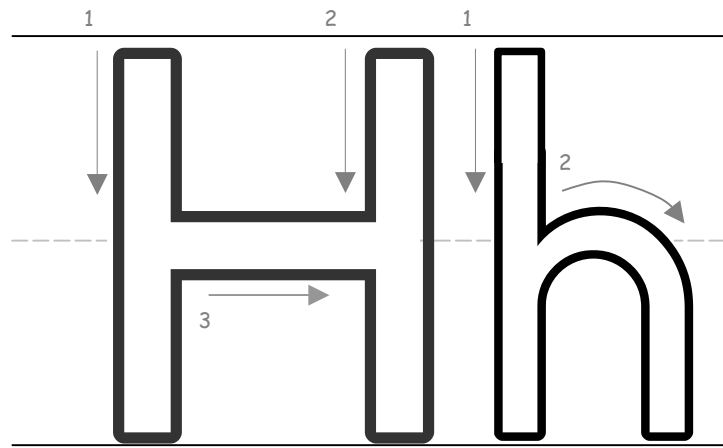

Color these things that start with H.

horse



house

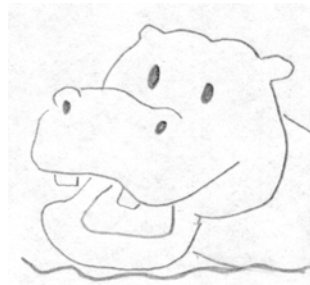

hippo

H

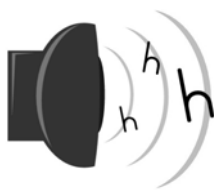

What sound does H make?

Circle the Hs.

H B P H I K H F H M
d h n r h k m h n h

Follow the pattern.

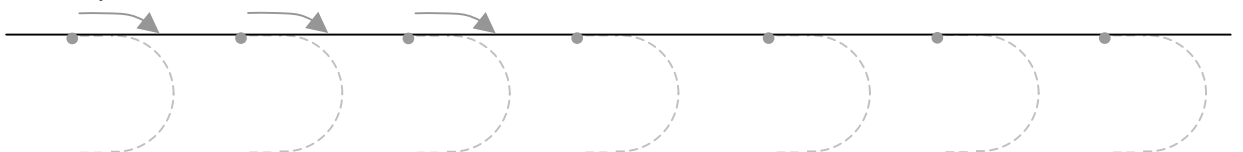

Trace I with your finger three times.

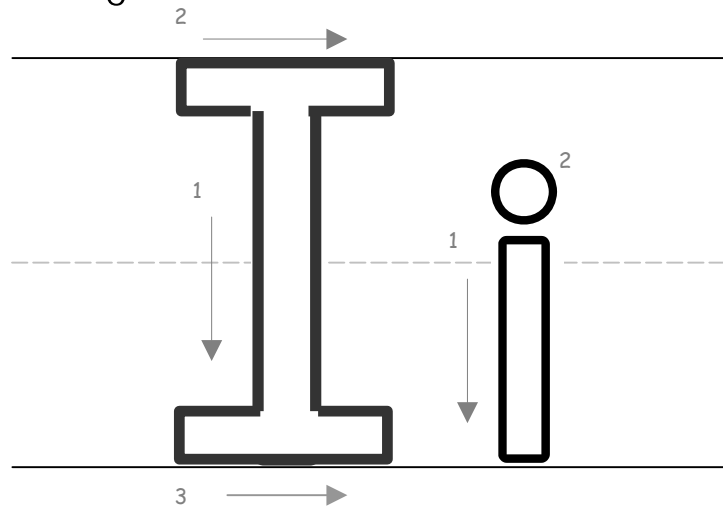

Color these things that start with I.

igloo

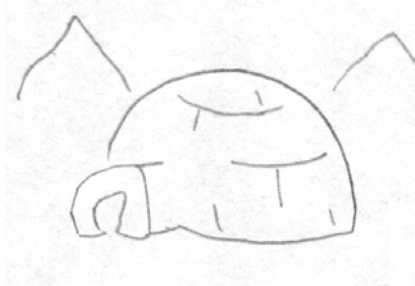

iguana

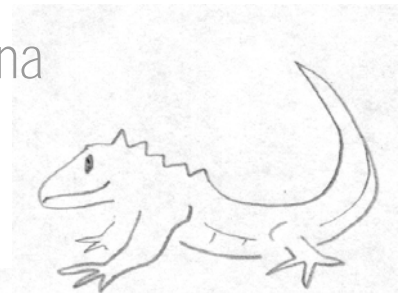

in

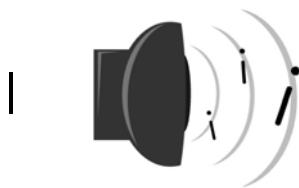
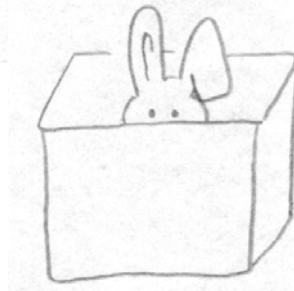

What sound does I make?

Circle the Is.

N I L I H J I T I P
i l j i y t e i s i

Follow the pattern.

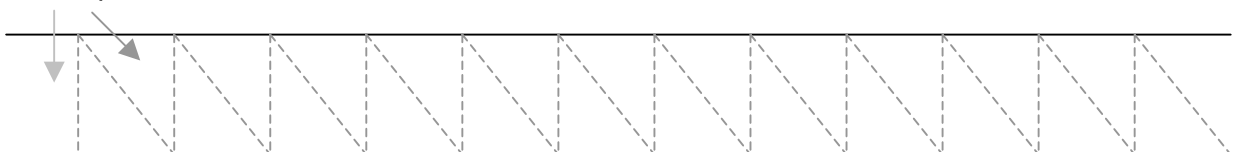

Trace J with your finger three times.

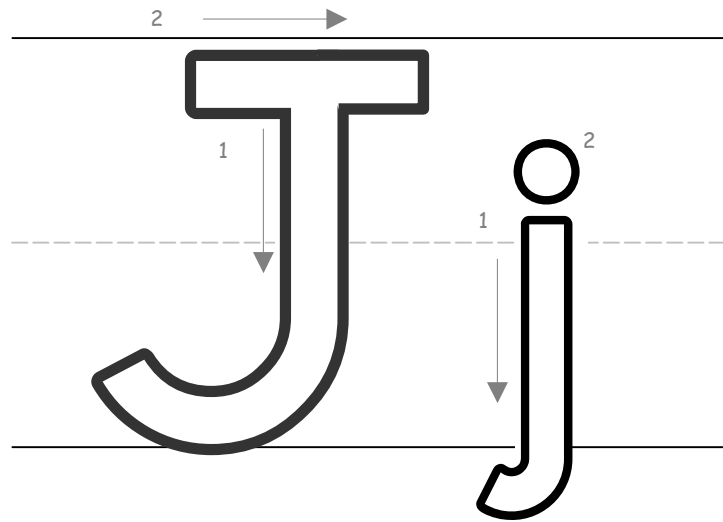

Color these things that start with J.

jump

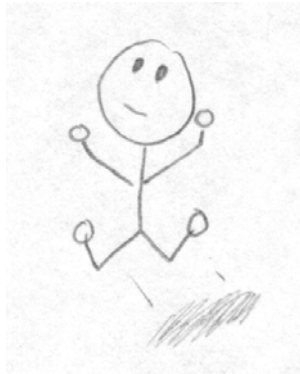

juice

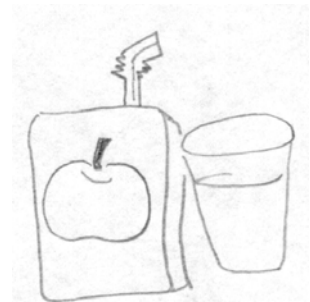

jam

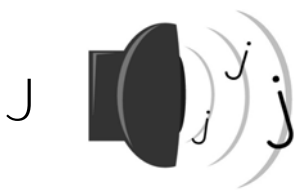

What sound does J make?

Circle the Js.

J I G J B L J T N J
i j g i j y q j p j

Follow the pattern.



Trace K with your finger three times.

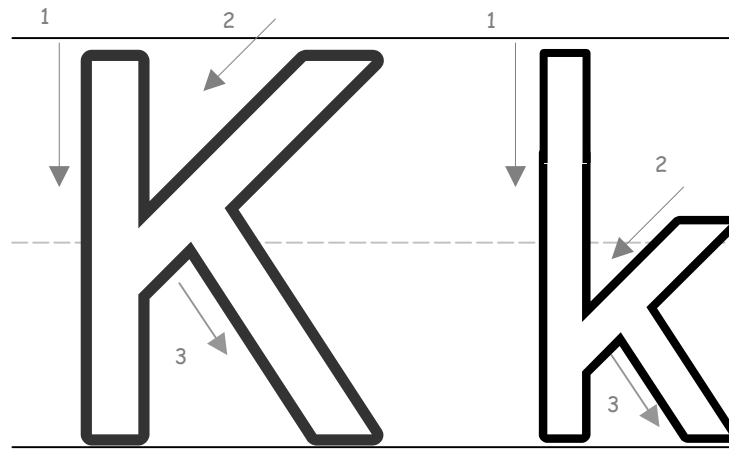

Color these things that start with K.

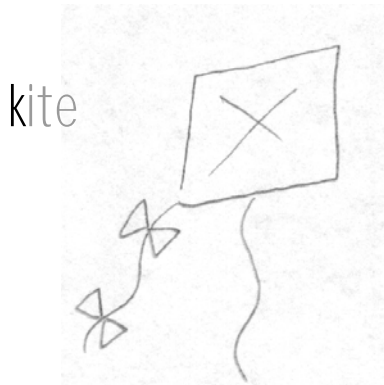

kangaroo



key



K

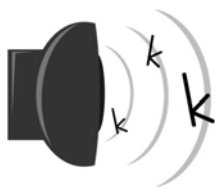

What sound does K make?

Circle the Ks.

K L J K P B K T X K
x k t k g r k f h k

Follow the pattern.

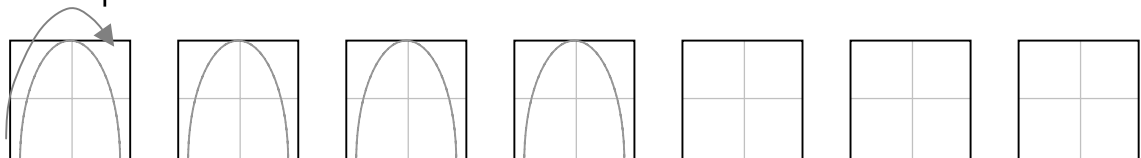

Trace L with your finger three times.

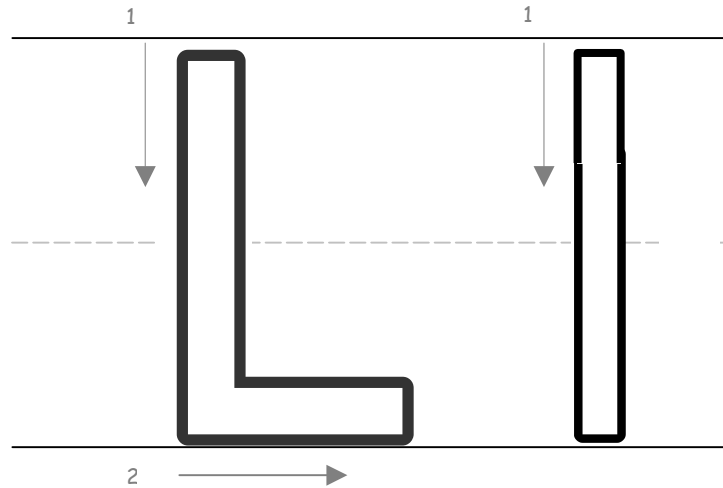

Color these things that start with L.

lion

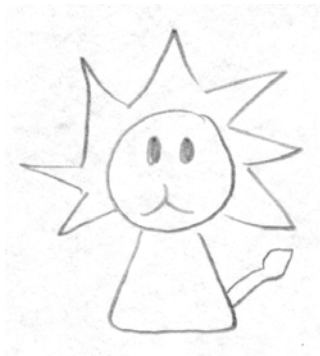

lamp



leaf

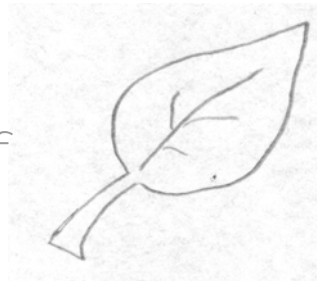

L



What sound does L make?

Circle the Ls.

H L T I L F L E Z L
l k t l i h l b l y

Follow the pattern.

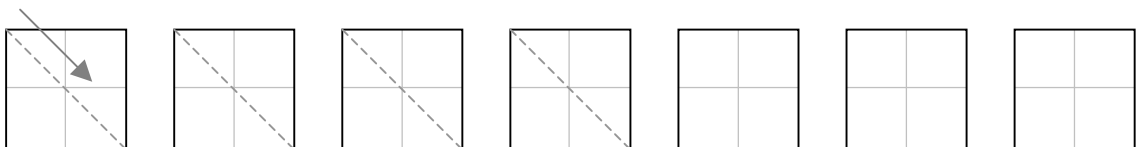

Trace M with your finger three times.

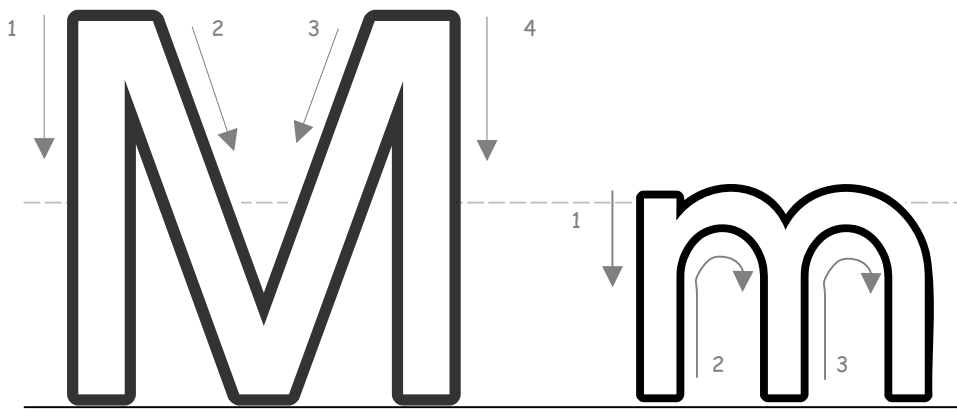

Color these things that start with M.

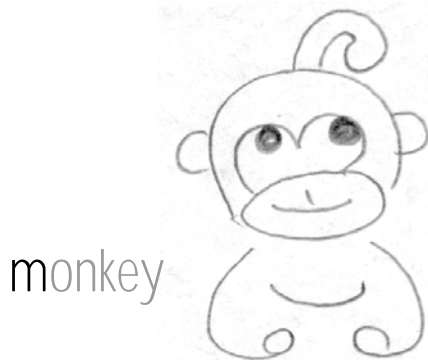

monkey



moon

mountain

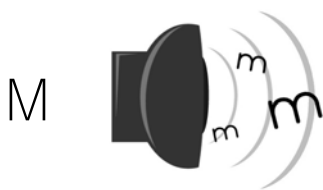

M

What sound does M make?

Circle the Ms.

M X H M W V M R M N
u m n w m x e m h m

Follow the pattern.

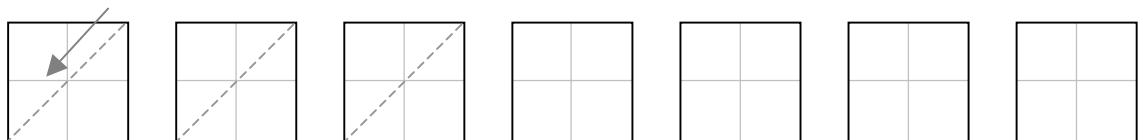

Trace N with your finger three times.

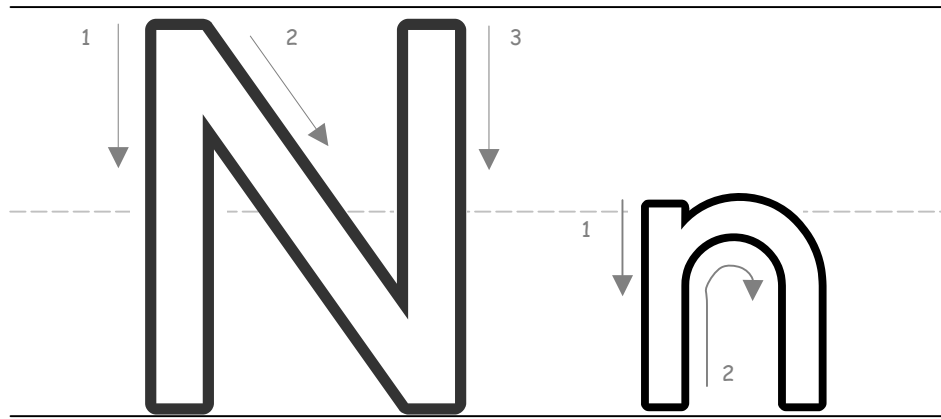

Color these things that start with N.

nurse



notebook



net

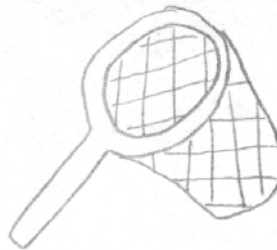

N

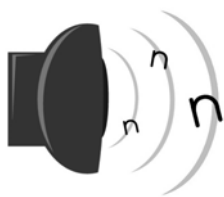

What sound does N make?

Circle the Ns.

M N L N X W N Z K N
n h m n y p u n r n

Follow the pattern.



Trace O with your finger three times.

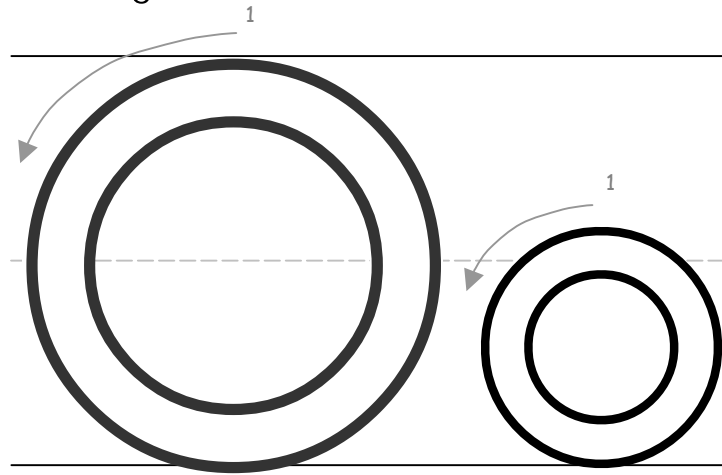

Color these things that start with O.

octopus

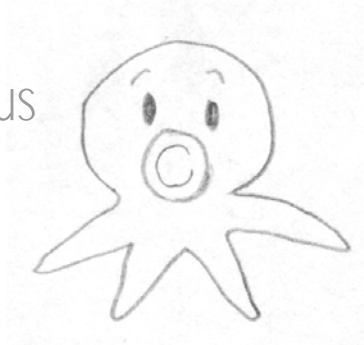

otter



ostrich

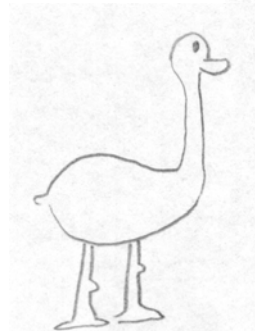

O

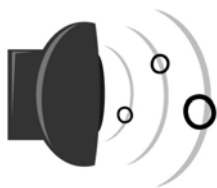

What sound does O make?

Circle the Os.

O C D O G Q O P U O
p o a b o c o e o d

Follow the pattern.

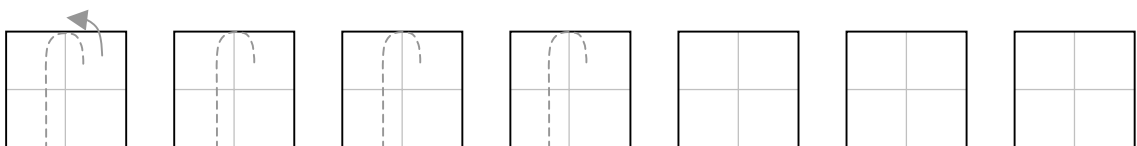

Trace P with your finger three times.

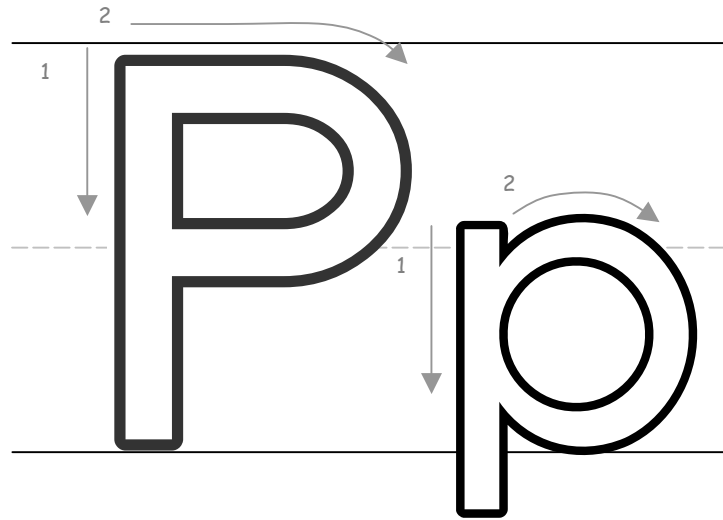

Color these things that start with P

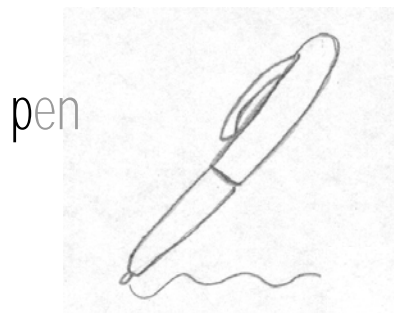

pumpkin

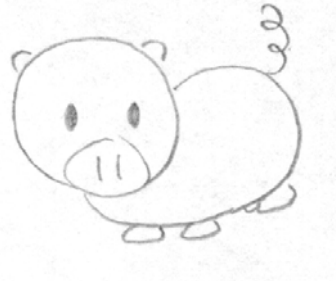

pig

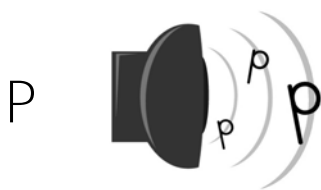

What sound does P make?

Circle the Ps.

B P D P L G R P F P
p d a p q b k p j p

Follow the pattern.

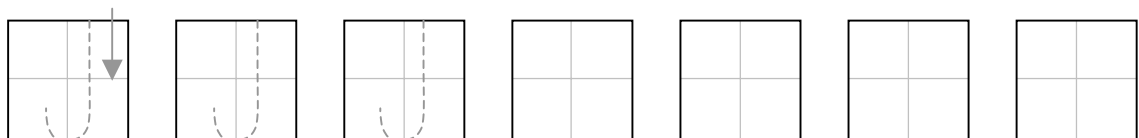

Trace Q with your finger three times.

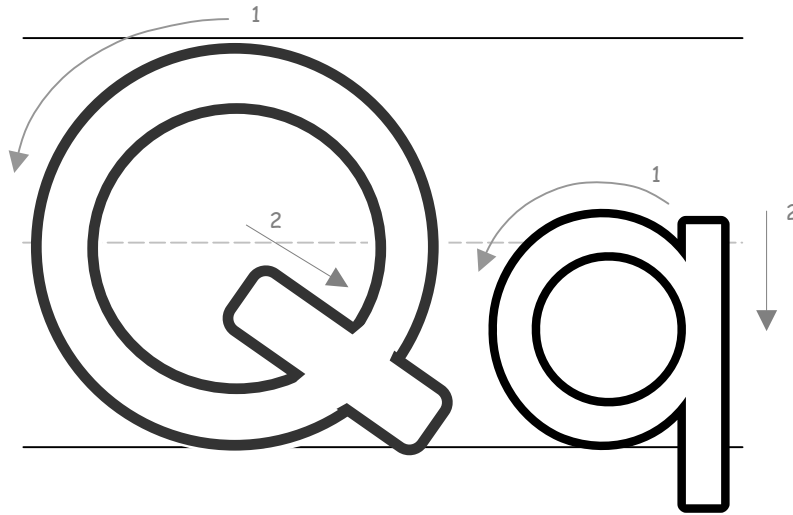

Color these things that start with Q.

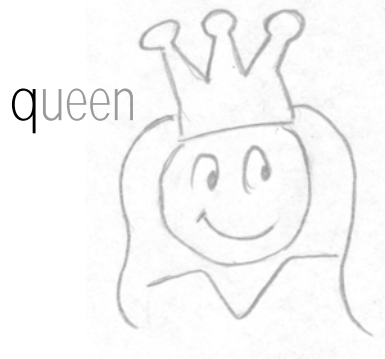

quiet

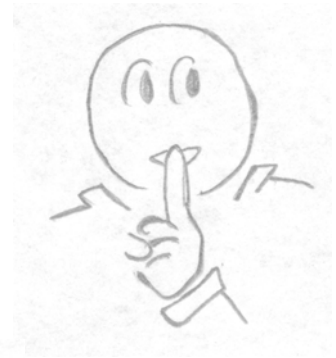

question
mark

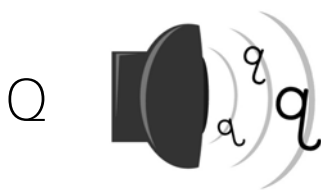

What sound does Q make?

Circle the Qs.

O Q D Q G R Q C Q B
q p d q j a q k b q

Follow the pattern.

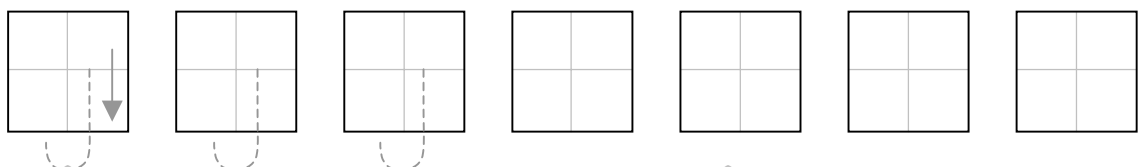

Trace R with your finger three times.

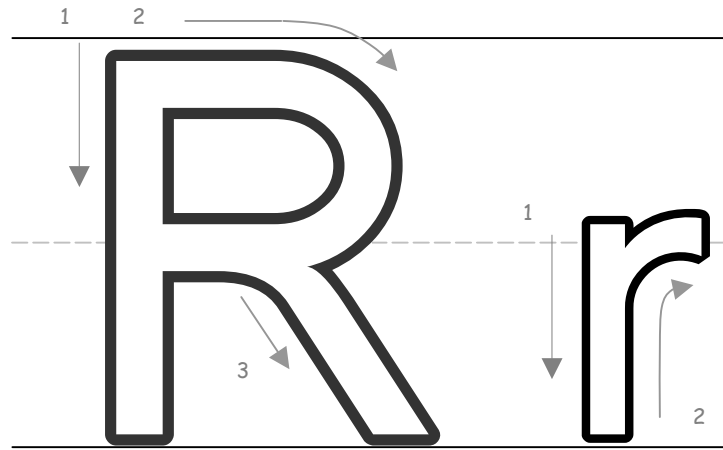

Color these things that start with R.

rabbit

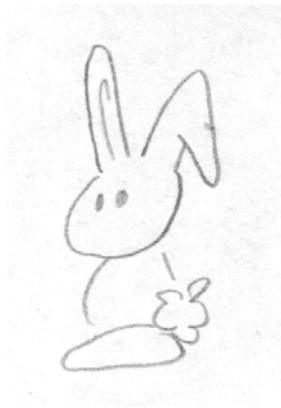

rocket

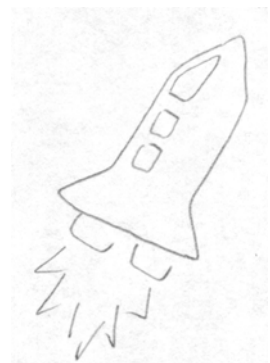

run



R

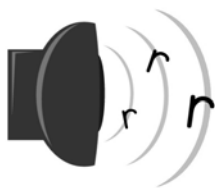

What sound does R make?

Circle the Rs.

P R K R B T R D R F
r v n r h m r t r f

Follow the pattern.

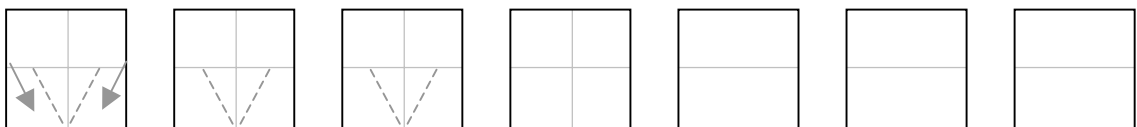

Trace S with your finger three times.

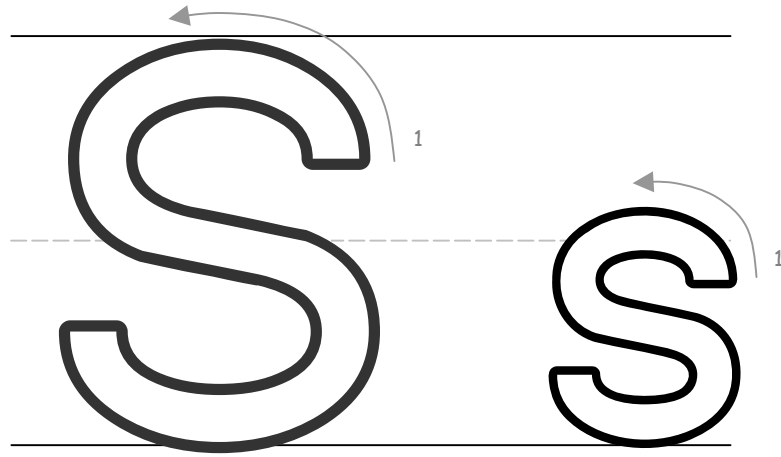

Color these things that start with S.

sun

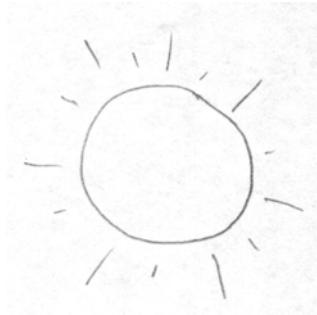

strawberry

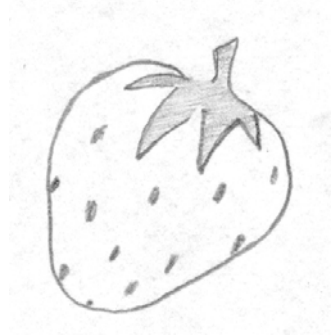

snake

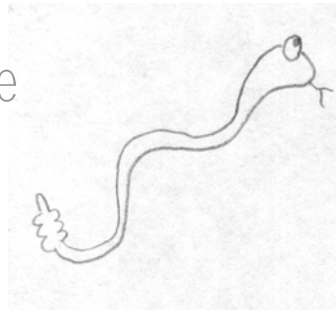

S

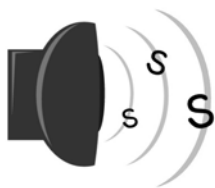

What sound does S make?

Circle the Ss.

Z S B S W Q S F S C
s z e s c s g s a z

Follow the pattern.

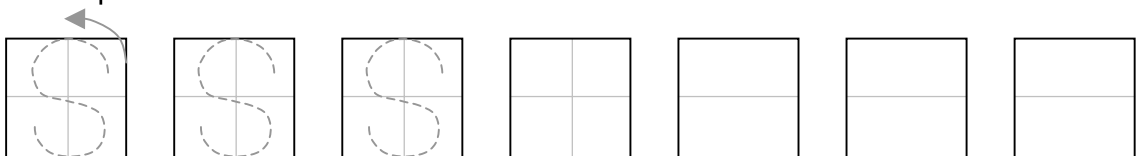

Trace T with your finger three times.

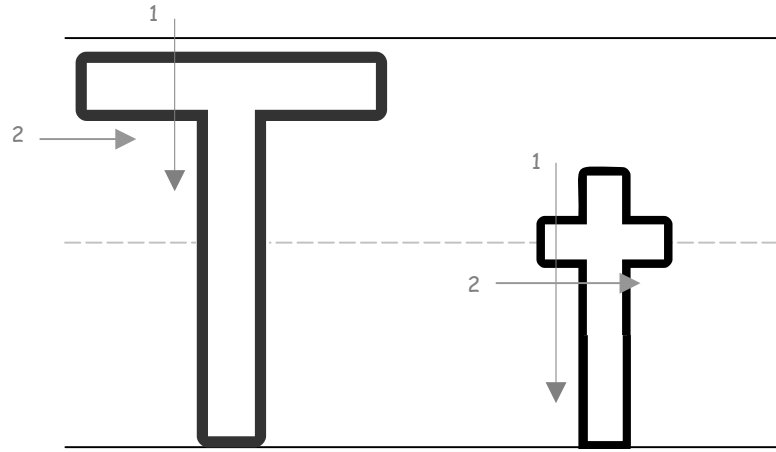

Color these things that start with T.

ten

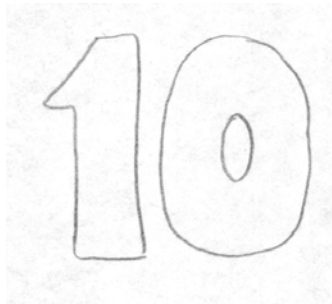

tree



turtle

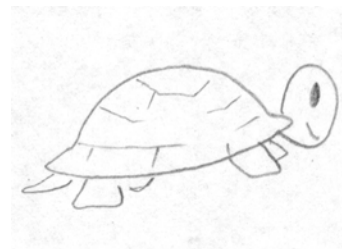

T

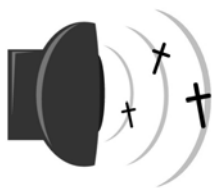

What sound does T make?

Circle the Ts.

T E T F I T Y L T F
r t f k t l x t b t

Follow the pattern.

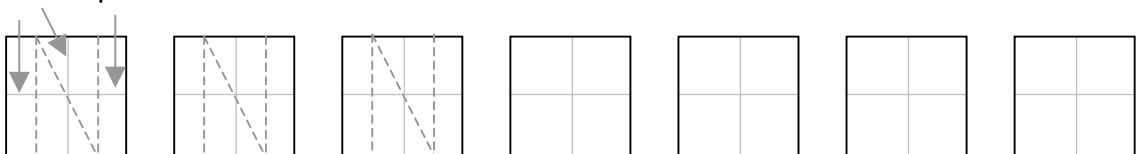

Trace U with your finger three times.

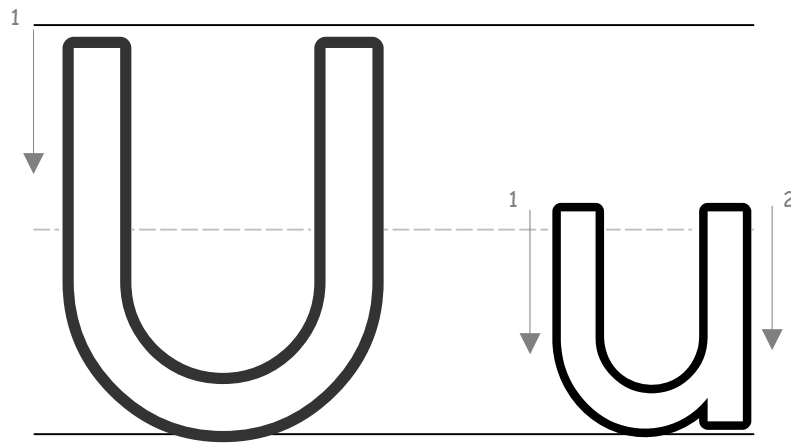

Color these things that start with U.

umbrella



up



upside
down



U

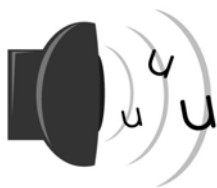

What sound does U make?

Circle the Us.

V U O U A V U W U D
u n u v o y u m u r

Follow the pattern.

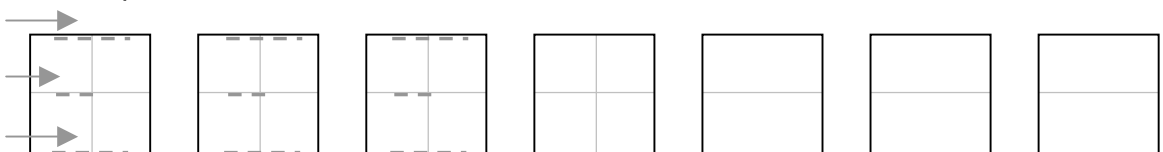

Trace V with your finger three times.

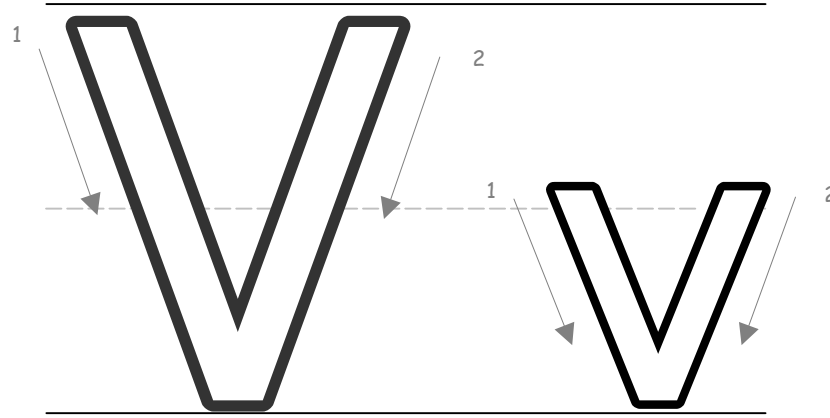

Color these things that start with V.

vampire



volcano



vacuum



V

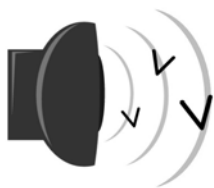

What sound does V make?

Circle the Vs.

V X V Y W K V N M V
t v u v r y v w x v

Follow the pattern.

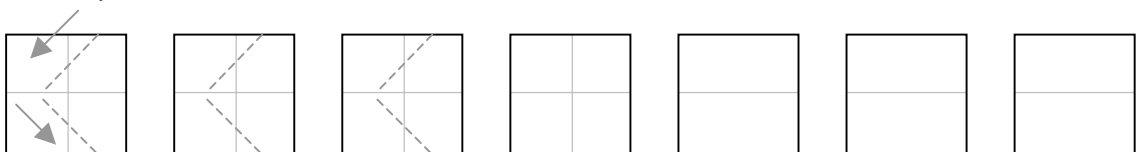

Trace W with your finger three times.

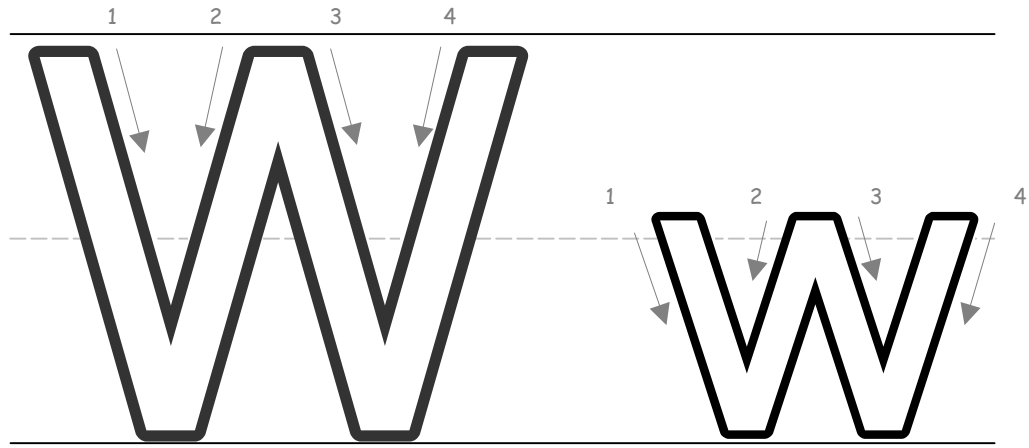

Color these things that start with W.

window

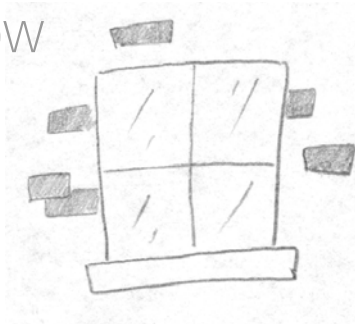

web



wink



W

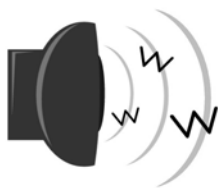

What sound does W make?

Circle the Ws.

X W V W M N W K Z W
w v x w m w y w p e

Follow the pattern.

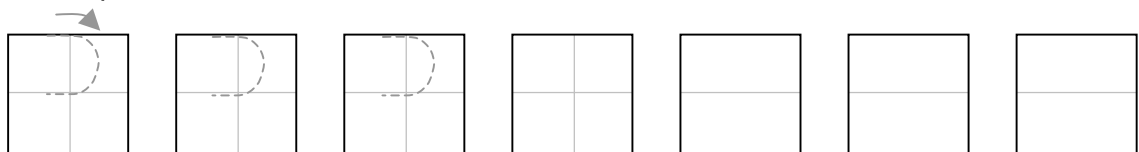

Trace X with your finger three times.

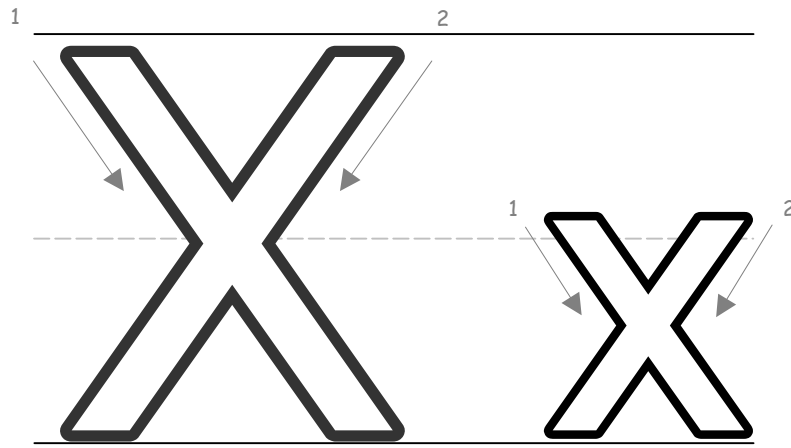

Color these things that **end** with X.

box

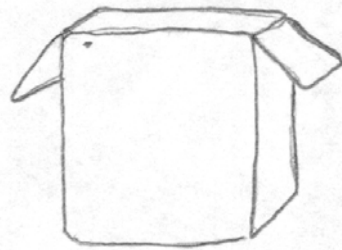

ax



mix



X

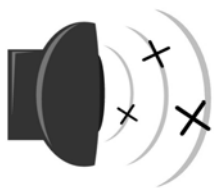

What sound does X make?

Circle the Xs.

V X K X H T X N Z X
x t v x y x w z x v

Follow the pattern.

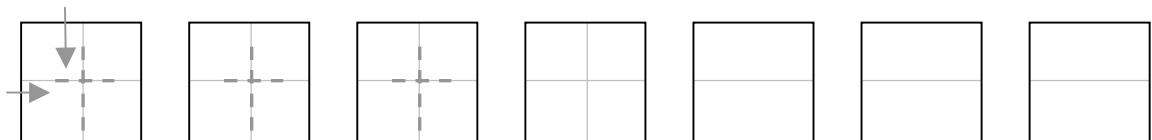

Trace Y with your finger three times.

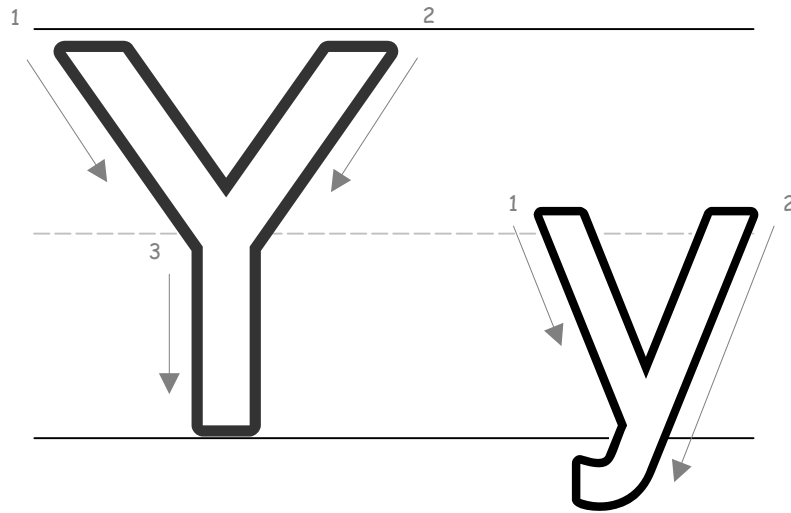

Color these things that start with Y.

yoyo



yawn



Y

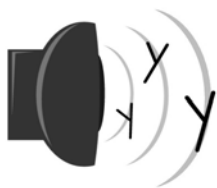

What sound does Y make?

Circle the Ys.

Y V Y X T K Y L Y R
v y g x w y q y j y

Follow the pattern.

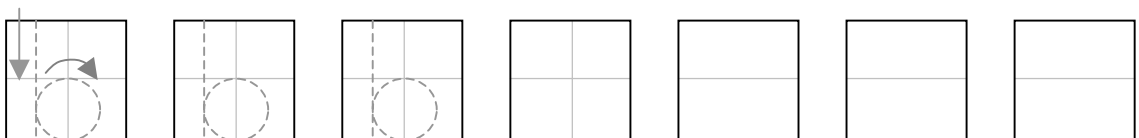

Trace Z with your finger three times.

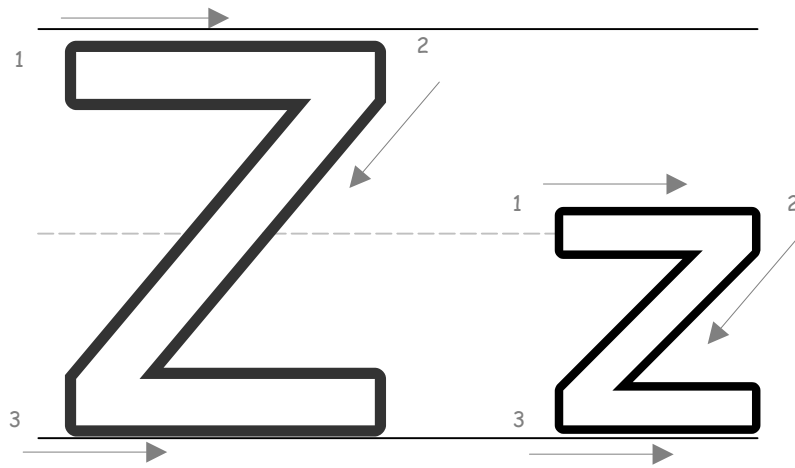

Color these things that start with Z.

zebra

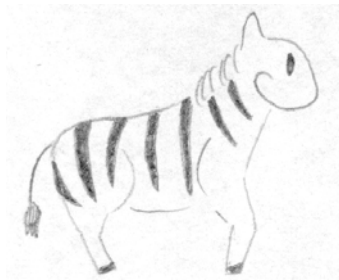

ZOO



zipper

Z

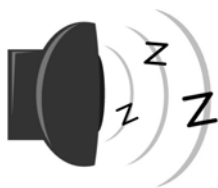

What sound does Z make?

Circle the Zs.

N Z Y C Z K N Z S Z
y z x z v s z h n z

Follow the pattern.

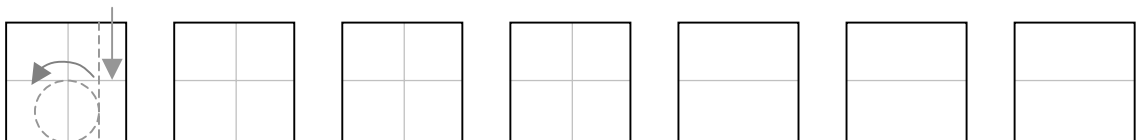

Fun Fonix is a phonics workbook series created by Mark Cox, owner and operator of [MES](http://www.funfonix.com). You can visit www.funfonix.com to find supporting materials, other phonics worksheets, worksheet makers, clipart to create your own worksheets, and resources for students as well.

Create additional materials to support this workbook quickly and easily at www.funfonix.com.

Fun Fonix materials and images are all copyright Mark Cox. No part or portion of this book or the Fun Fonix.com site materials may be used without permission. For a full explanation of acceptable use of Fun Fonix materials, see the MES End User License Agreement at <http://www.mes-english.com/eula.php>

Happy teaching!
Mark Cox

Printable books in the Fun Fonix Series:

Fun Fonix ABC: introduction to the alphabet and phonics sounds

Fun Fonix Intro: hard consonants and short vowels; initial sounds

Fun Fonix Book 1: short vowels

Fun Fonix Book 2: consonant diagraphs: ck, ng, sh, ch, th, qu, wh

Fun Fonix Book 3: long vowels with silent e

Fun Fonix Book 4: vowel combinations: ee, ea, ai, oo, oa

Check www.funfonix.com for the most current details.